

**Łańcuchy rowerowe i motorowerowe wg PN-77/M-84168**

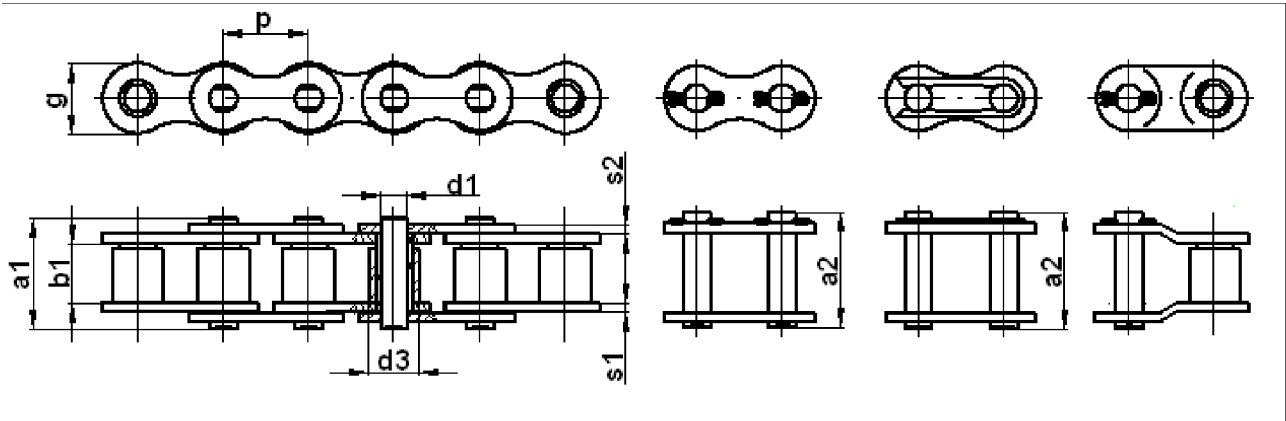

ISO No.	P		b <sub>1</sub> mm min	d <sub>1</sub> mm max	d <sub>3</sub> mm max	a <sub>1</sub> mm max	a <sub>2</sub> mm max	g mm max	S <sub>1</sub> mm	S <sub>2</sub> mm	FB daN min	q kg/m
	mm	inch										
081	12,70	1/2"	3,30	3,66	7,75	10,20	11,70	10,00	1,00	1,00	820	0,30
083	12,70	1/2"	4,88	3,66	7,75	10,70	12,30	9,90	1,00	1,00	840	0,37
084	12,70	1/2"	4,88	4,18	7,75	13,00	14,30	10,90	1,40	1,40	1050	0,48
085	12,70	1/2"	6,40	4,18	7,75	14,50	15,90	10,90	1,40	1,40	1575	0,52
T085*	8,50	-	4,75	3,30	5,00	13,20	-	8,60	1,80	1,80	1100	0,43
T095*	9,525	3/8"	9,50	4,50	6,00	18,60	-	9,07	1,80	1,80	1200	0,60
420	12,70	1/2"	6,35	3,96	7,77	14,75	15,92	12,00	1,50	1,50	1600	0,56
428	12,70	1/2"	7,94	4,50	8,51	16,40	17,80	12,28	1,50	1,50	1800	0,70
428H	12,70	1/2"	7,94	4,50	8,51	18,45	19,75	12,08	2,00	2,00	2100	0,78
520	15,875	5/8"	6,35	5,08	10,16	17,25	18,56	15,09	2,03	2,03	2220	-

\* Łańcuchy tulejkowe  
 FB - Siła zrywająca  
 q - Waga